

# REINHOLD ENVIRONMENTAL<sup>®</sup>



## **2025 Reinhold/PCUG Round Table Presentation**

Hosted by AEP and Buckeye Power

in The Hilton Columbus Polaris Hotel, Columbus, OH

on June 23-24, 2025

All presentations posted on this website are copyrighted by **REINHOLD ENVIRONMENTAL<sup>®</sup>** (RE). Any unauthorized attempts to print, to download, to modify, to incorporate into other presentations, to link to other websites or to obtain copies for any other uses than the training of attendees to RE Conferences is expressly prohibited unless approved in writing by RE or the original presenter. RE does not assume any liability for the accuracy or contents of any materials in this library which were presented and/or created by persons who were not employees or subcontractors of RE.



*Transforming the Future of Power Technology*

# ESP Electrical 501

## Reinhold Round Table 2025

Paul Leanza – Director, ESP Field Services Operation



# Objective

**The purpose of this talk is to provide a basic understanding of the power supplies used on Electrostatic Precipitators. We will cover the following topics:**

- **Primary Function of the Power Supply**
- **Primary Function of the Control**
- **Power Supply Types Currently Available**
- **Improvements in Controls**

## Deutsch-Anderson Equation

$$\eta = 1 - e^{-w(A/Q)}$$

Where:  $\eta$  = collection efficiency of the precipitator  
 $e$  = base of natural logarithm = 2.718  
 $w$  = migration velocity, cm/s (ft/sec)  
 $A$  = the effective collecting plate area of the precipitator, m<sup>2</sup> (ft<sup>2</sup>)  
 $Q$  = gas flow through the precipitator, m<sup>3</sup>/s (ft<sup>3</sup>/sec)

---

## Particle-Migration Velocity

$$w = \frac{d_p E_o E_p}{4\pi\mu}$$

Where:  $d_p$  = diameter of the particle,  $\mu\text{m}$   
 $E_o$  = strength of field in which particles are charged  
(represented by peak voltage), V/m (V/ft)  
 $E_p$  = strength of field in which particles are collected  
(normally the field close to the collecting plates), V/m (V/ft)  
 $\mu$  = gas viscosity, Pa • s (cp)  
 $\pi$  = 3.14

The primary function of the power supply is:

To provide a source of High Voltage for the Discharge Electrodes in the ESP

This high voltage charges the ash particles for the collection process.

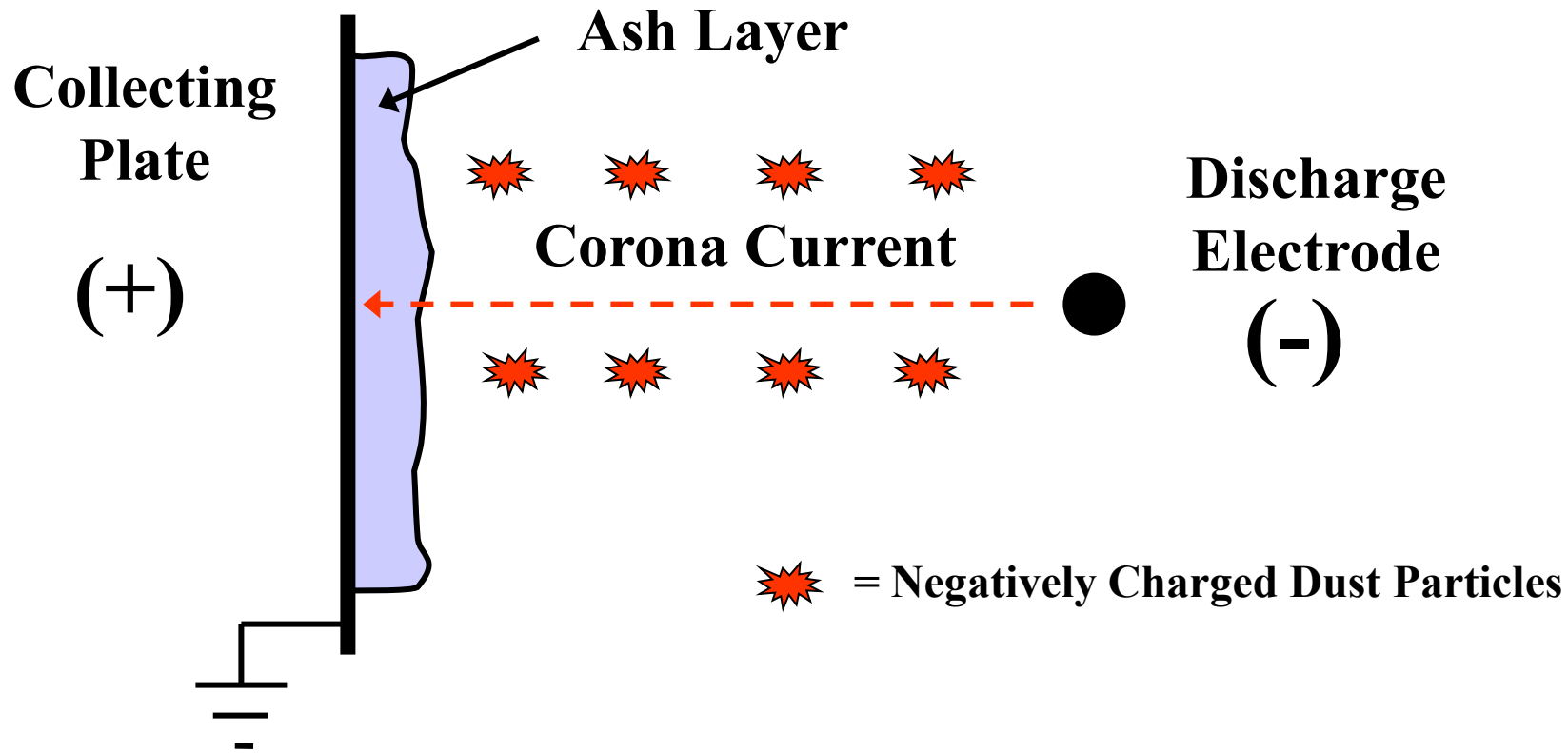

**The primary function of the control is:**

- 1. To prevent the power supply from operating at levels above it's nameplate rating.**
- 2. To protect the power supply from varying load conditions within the ESP, such as short circuits, open circuits, and sparking/arcng.**
- 3. To provide the highest possible voltage to the ESP for any given load condition.**

## **Power Supply Types Available:**

- **Single phase T/R Set with CLR and SCR control**
- **Three phase T/R Set with CLR and SCR control**
- **Switchmode power supply utilizing IGBT's to generate high or mid frequency output to a T/R set.**
- **Pulser unit that generates a narrow high voltage pulse that gets imposed on a base high voltage waveform.**

- Single phase T/R Set with CLR and SCR control

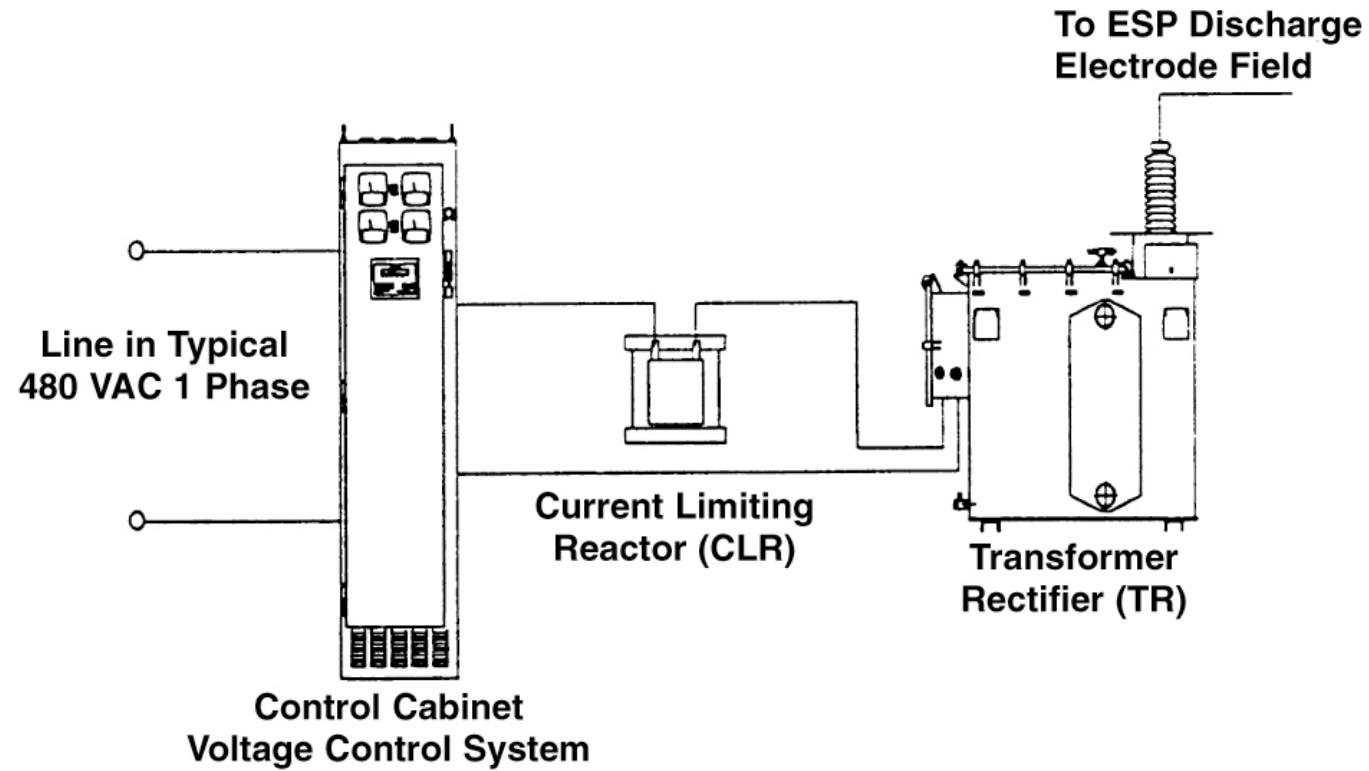

- Utilize Silicon Controlled Rectifiers (SCR) to vary the 480 VAC power

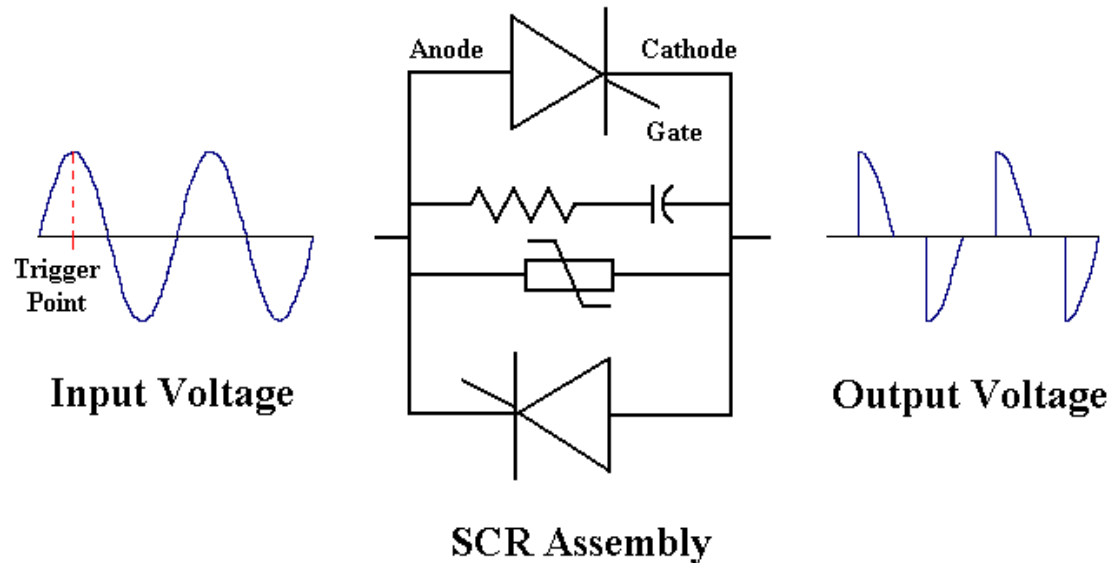

Two conditions must be satisfied for the SCR to conduct.

- The anode of the SCR must be positive with respect to the cathode.
- A trigger signal must be applied to the gate.

The SCR will continue to conduct until the current passing through it, goes to zero.

- By varying the time delay between when the voltage goes positive and the trigger is applied, the output of the SCR will change.

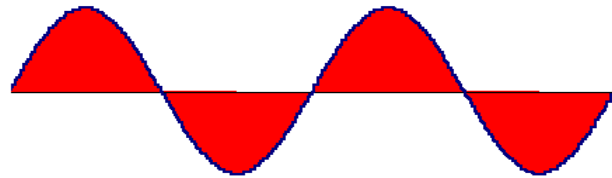

180 °

**Maximum Output from  
the SCR Assembly**

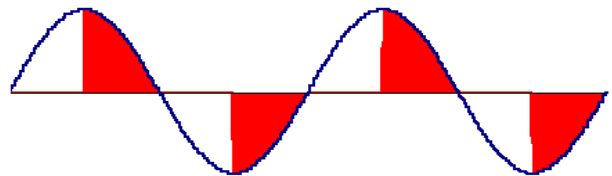

90 °

**Approx. Half Output from  
the SCR Assembly**

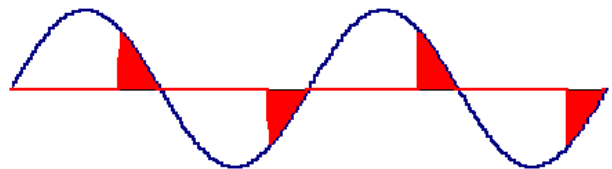

45 °

**Approx. Quarter Output  
from the SCR Assembly**

- The varying 480 VAC gets sent to the T/R set

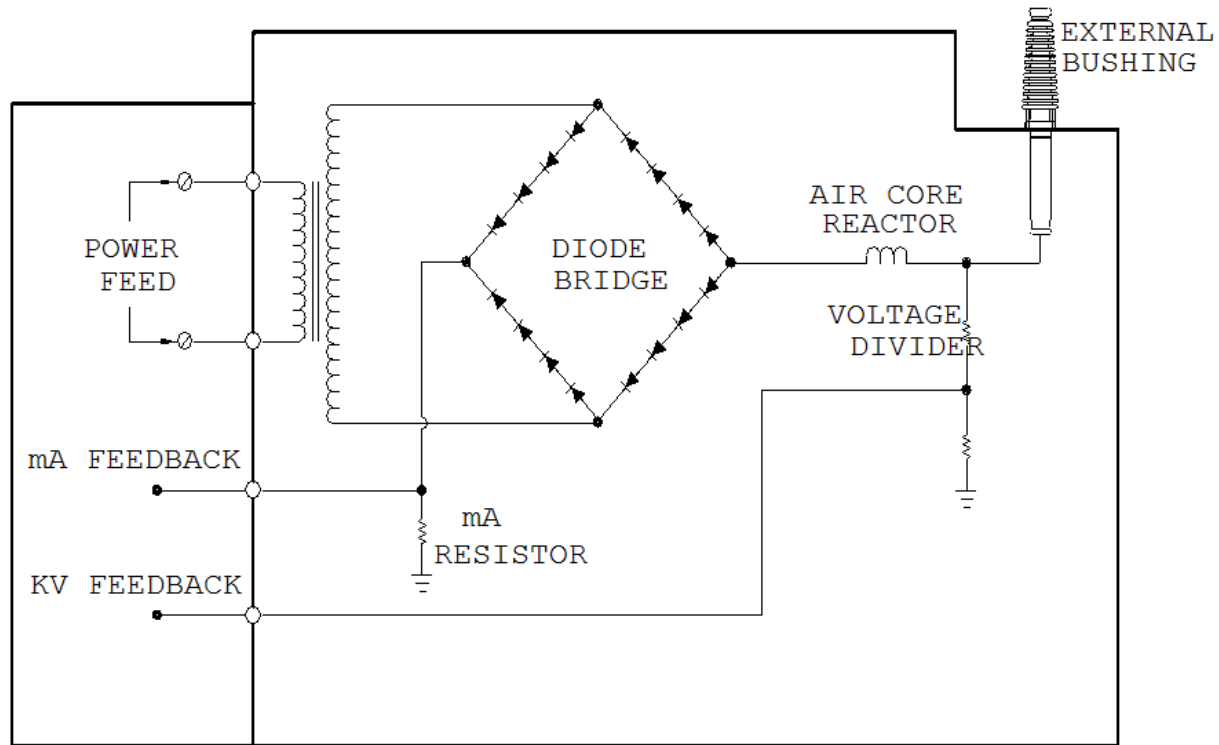

# Output Waveform

**kVDC**

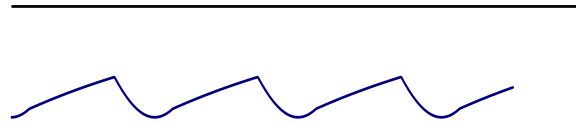

**mADC**

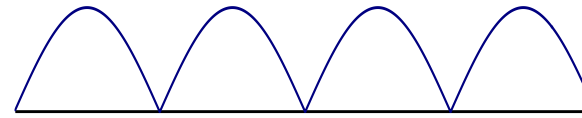

**% Ripple kVp-p = approx. 35% - 45% depending upon load & SCR conduction angle**

**Ripple Frequency = 120 Hz for 60 Hz supply**

- Three phase T/R Set with CLR and SCR control

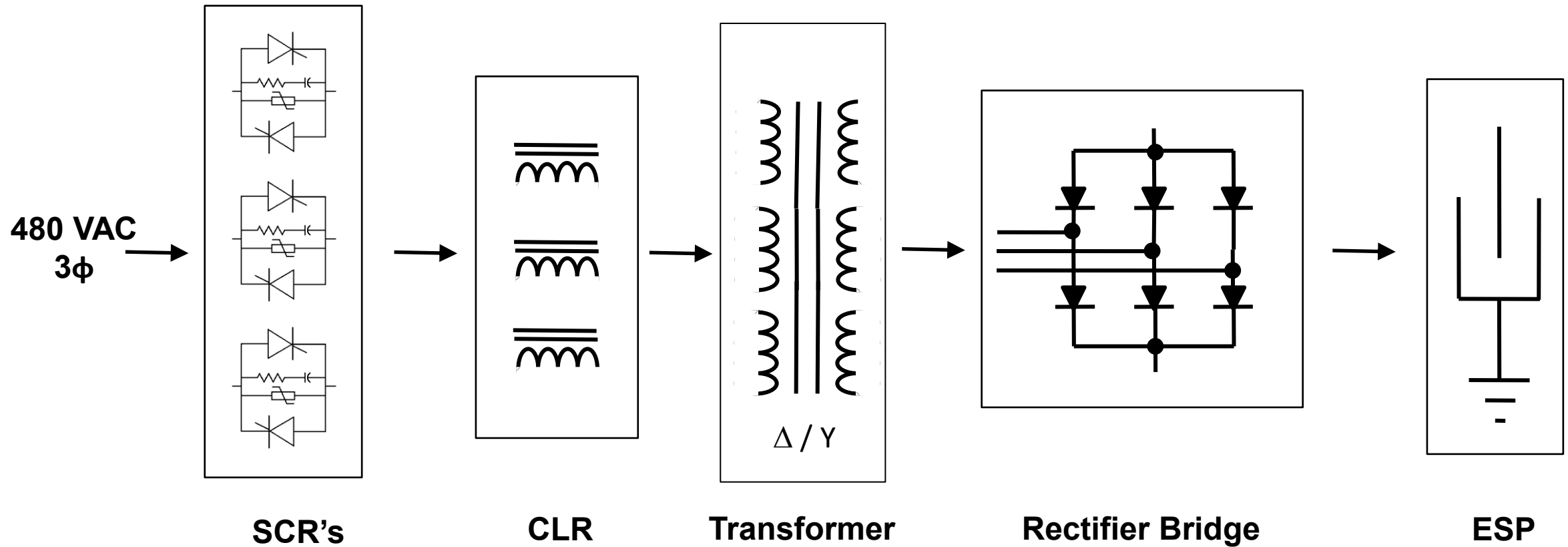

## Output Waveform

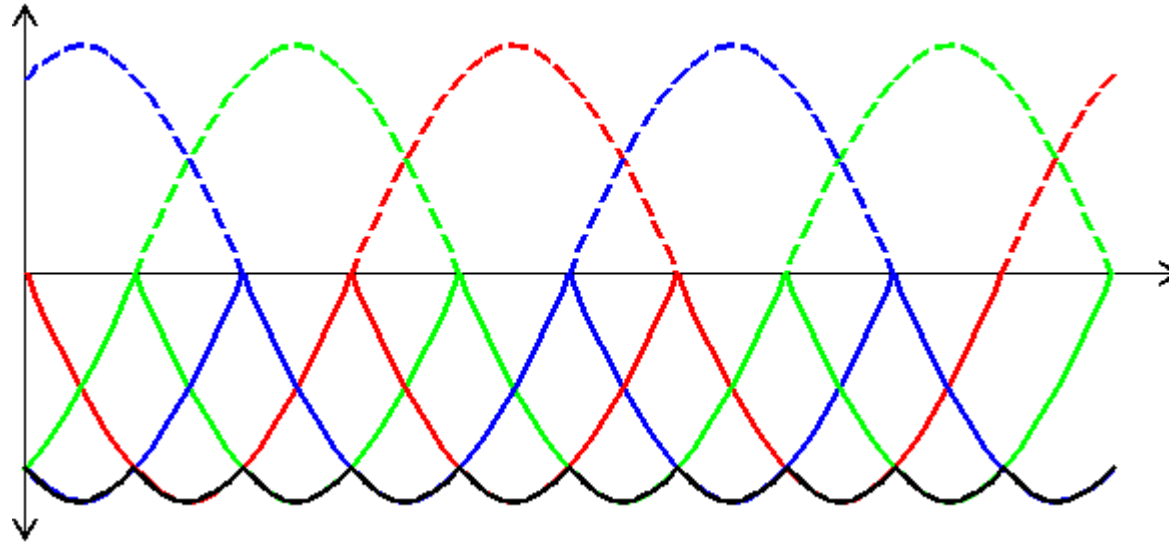

**% Ripple kVp-p = 5% - 15% depending upon load and SCR conduction angle**

**Ripple Frequency = 360 Hz for 60 Hz supply**

- **Switchmode Power Supply – includes mid frequency & high frequency units**

**They utilize IGBT's (Isolated Gate Bi-polar Transistors) to convert to higher than line frequencies**

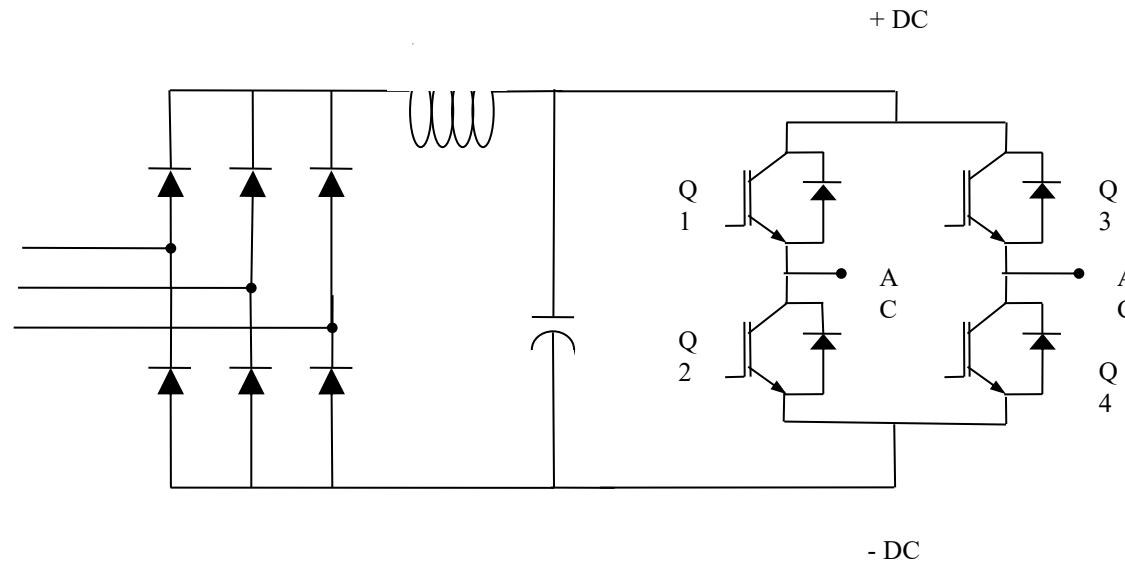

**The IGBT is a power electronic solid-state switch that turns on and off with very low power input yet switches high values of current and voltage. The IGBT can switch at many tens of kHz.**

# Output Waveforms

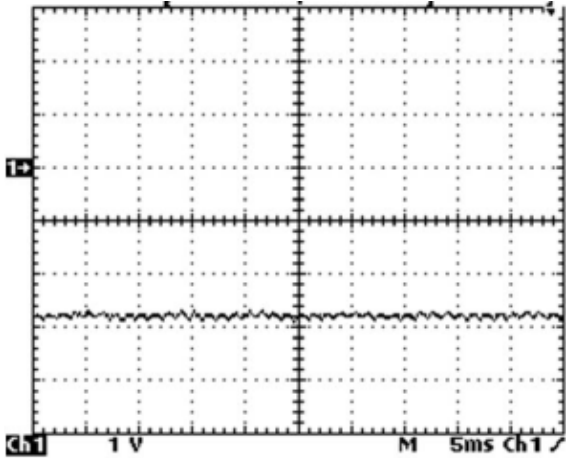

Mid frequency – 400 Hz

%Ripple kVp-p = 5-7%

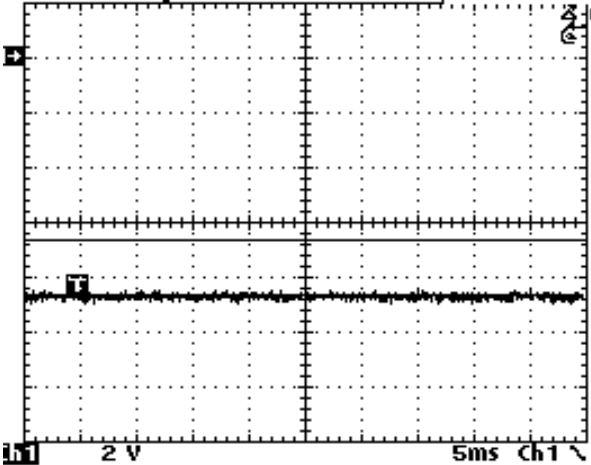

High frequency – 25 kHz

%Ripple kVp-p = 3-5%

# Pulsers

Starts with a base HV output from a T/R set

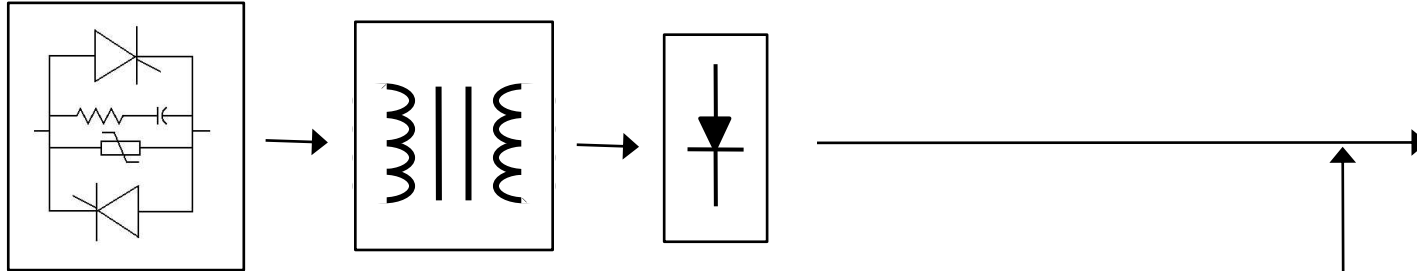

Imposes high frequency pulses on the base waveform

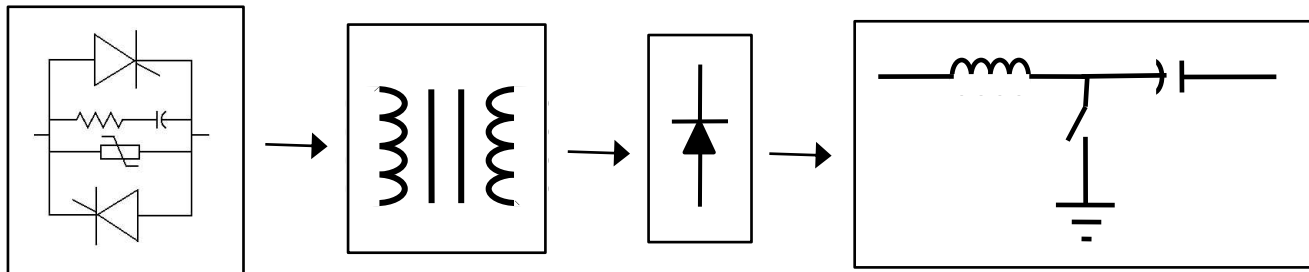

Primarily used for high resistivity loads where back corona is present

# Output Waveforms

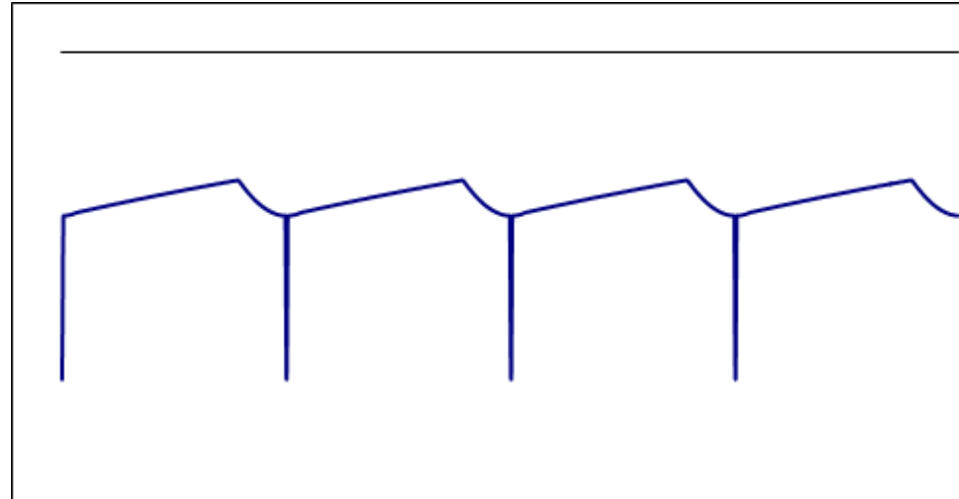

**Spark/Arc Control:** (Note: as each control manufacturer tends to have their own specific spark/arc definitions, parameter terms, and control responses, this portion will be based on the NWL control.)

**Definitions (shown with SCR waveforms):**

**Spark** - A relatively small discharge within the precipitator that will self extinguish with no increase in the base waveform current.

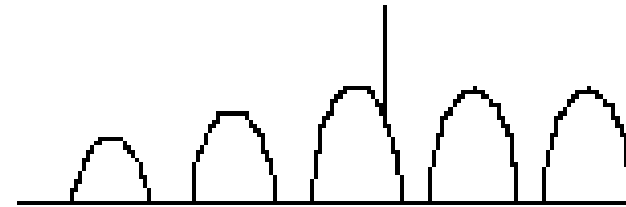

**Arc** - A large disruptive discharge within the precipitator that will not self extinguish. It causes continual fault current to flow.

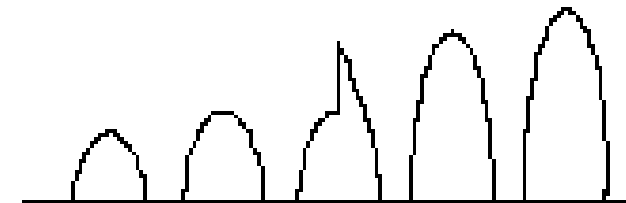

## Spark Response

The conduction angle of the SCR's is reduced an adjustable amount on the next half cycle. This "setback" will reduce the KVDC in the precipitator to stop another spark from occurring. A "slow ramp" then increases the voltage back to the original sparkover point.

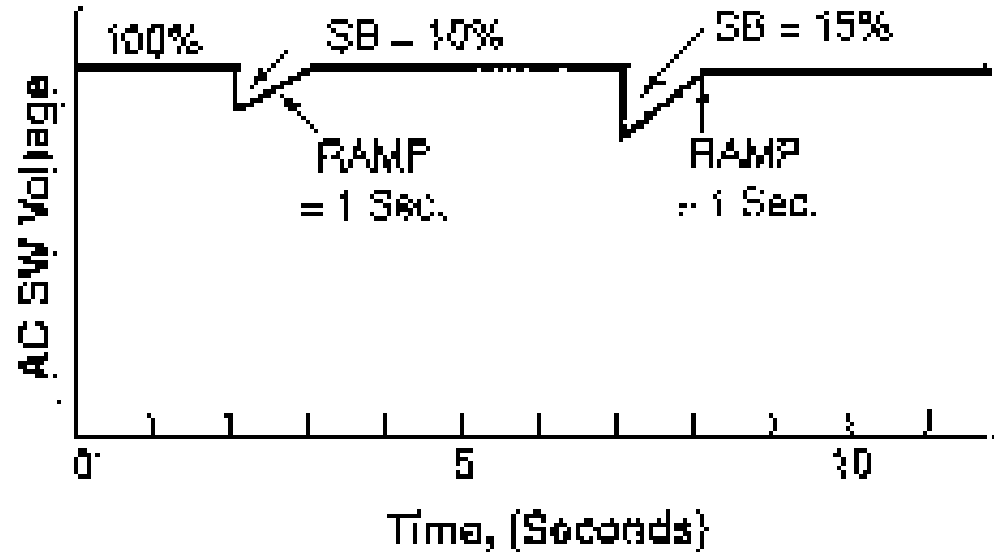

## Arc Response

The SCR's are turned off during the next half cycle. They stay off for the duration of the quench time. This reduces the KVDC to zero allowing the arc to extinguish or "quench" itself. A "fast ramp" then quickly increases the voltage to the "spark setback" level where the "slow ramp" then increases it back to the arc over voltage.

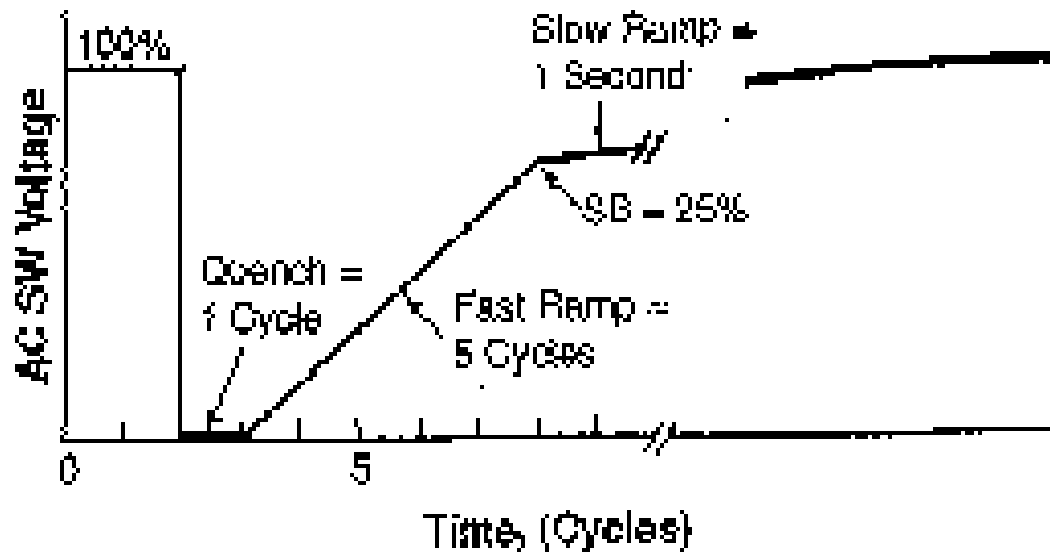

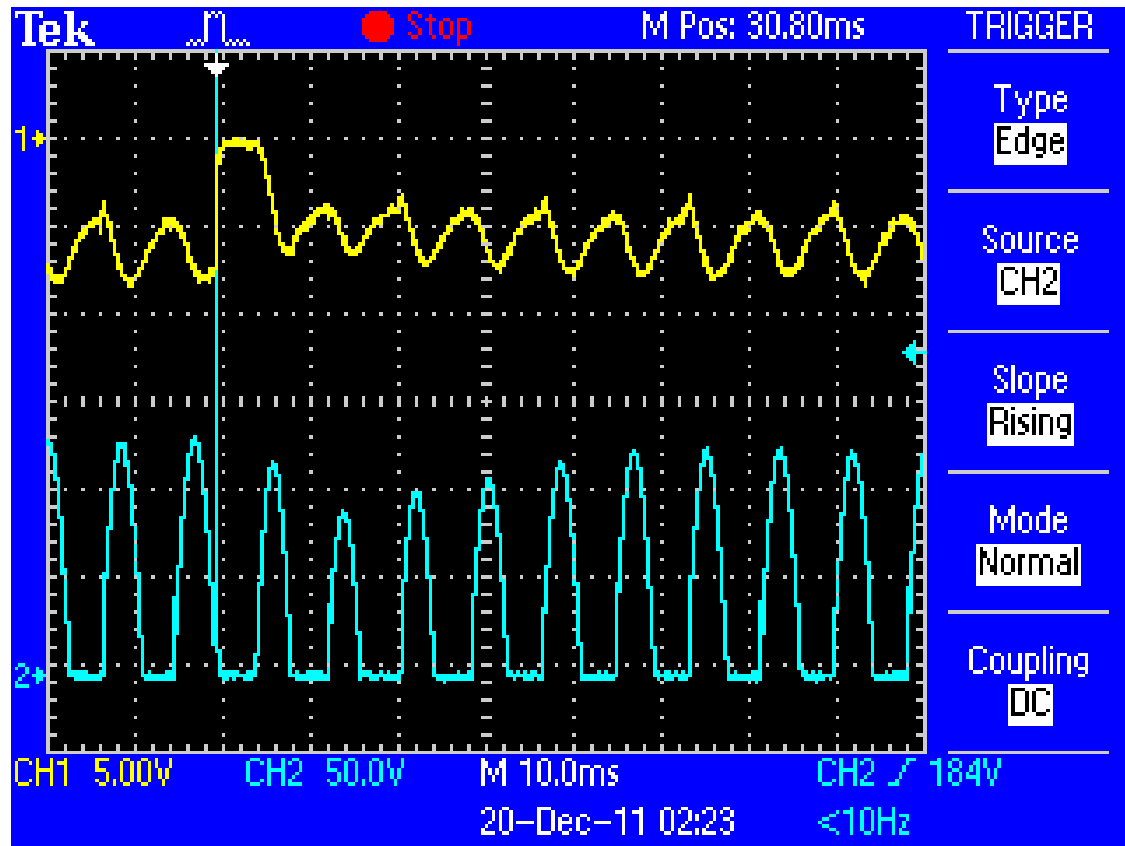

**SCR Control Spark Response**

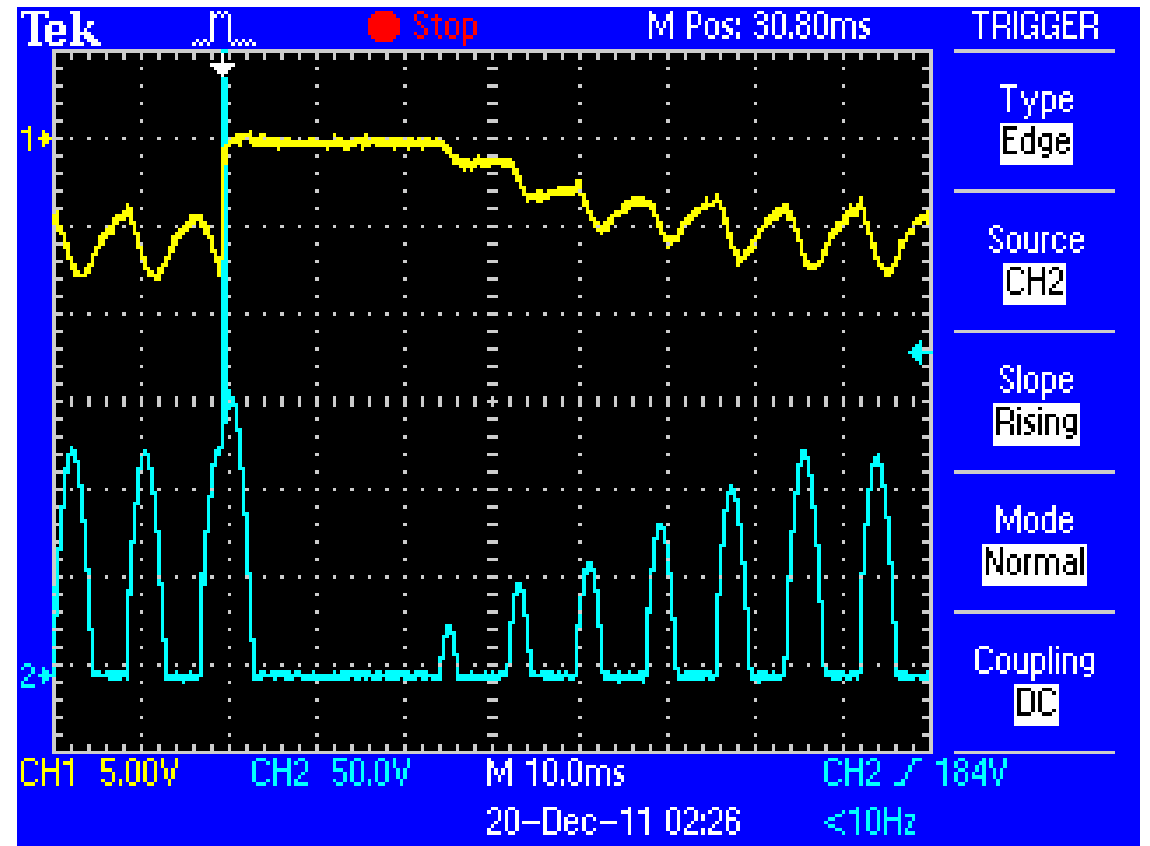

**SCR Control Arc Response**

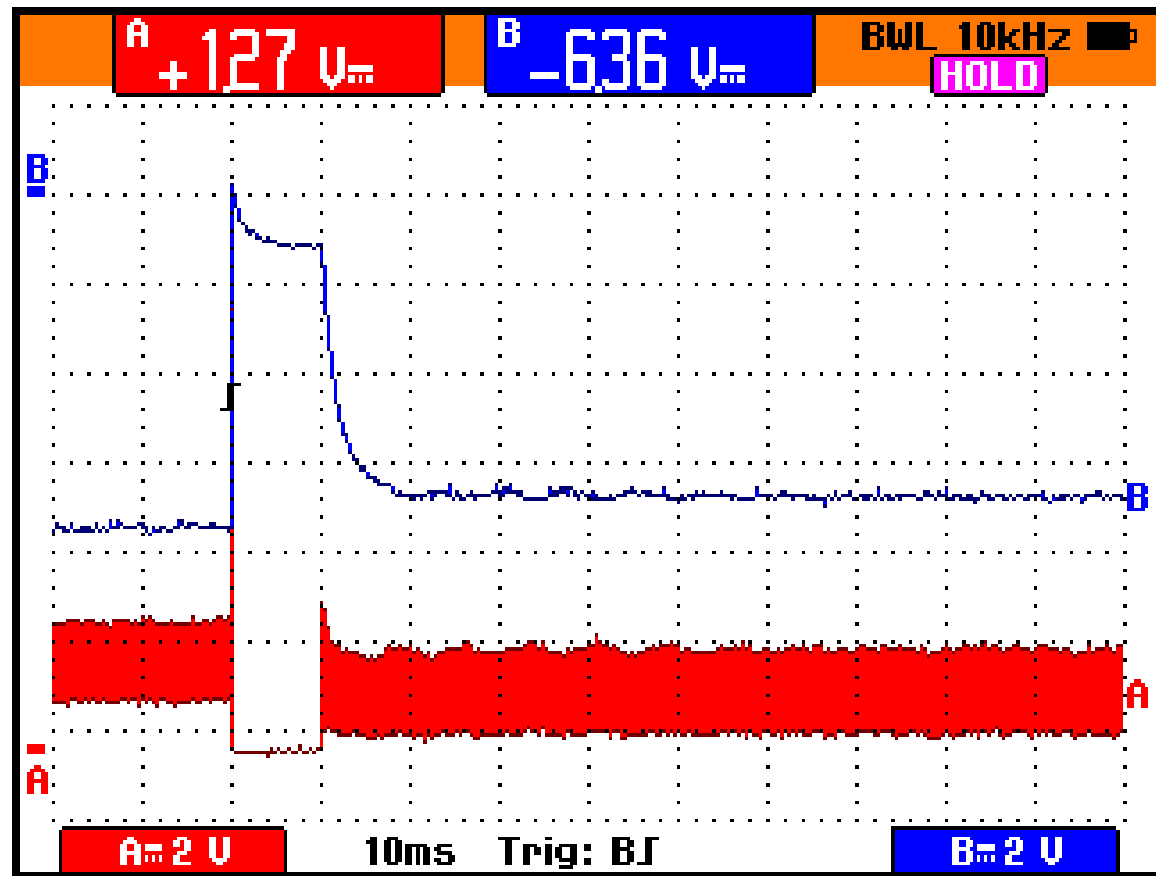

Switchmode Spark Response

# Control Improvements

- **Processor speed and data handling**-today's modern processors operate at speeds in excess of and by using DSP (Digital Signal Processing), it allows the control designers to do things that 10 years ago seemed impossible.
- **Communication-protocols compatibility.**
- **Integration**-the ability to interface with rapper controls and other process related equipment to automate changes to operations.
- **WEB integration**-allows users to access the ESP controls from anywhere.

# What is a SMPS?

- It is an integrated power supply with the control section and high voltage tank section mounted together.
- It utilizes the latest in power electronics (IGBTs - Insulated Gate Bipolar Transistors) to enable very rapid spark/arc detection and suppression.
- The IGBT's operate at frequencies up to 25 khz to supply an almost ripple free DC output to the ESP.

# SMPS Block Diagram

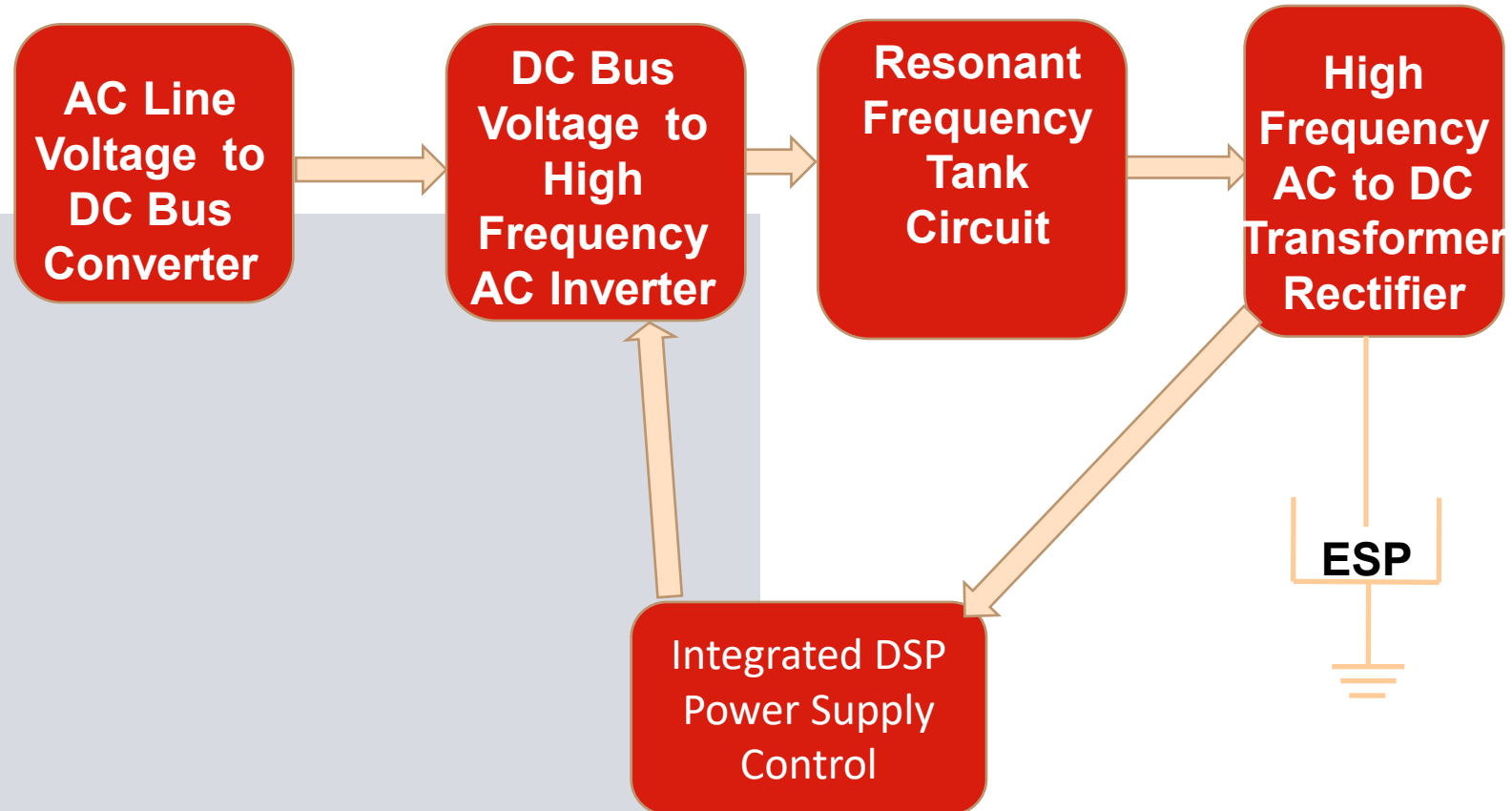

# Packaging Style Determined By Unit Rating and Ground Switch Configuration



## Key Features & Benefits of SMPS

- Uses three phase input power so the plant load is always balanced.
- Use of IGBTs provide faster spark response and better control in IE mode.
- Circuit topology is such that the power factor is much higher. It takes less kVA to produce the same power output.
- Reduced output ripple over the full operating range will increase the average kV and mA delivered to the ESP. This will increase the migration velocity and the collection efficiency of the ESP.
- Due to the high frequency design, the HV tank is much smaller than a equivalent size 50/60 hz design.
- The integrated control design eliminates the need for a ESP control room and reduces the cost of installation.
- Communicates with plant DCS over most of the common industrial protocols (Ethernet IP, Modbus TCP, Modbus RTU, Profinet, Profibus, DeviceNet, ControlNet, etc.)

# INCENTIVIZATION

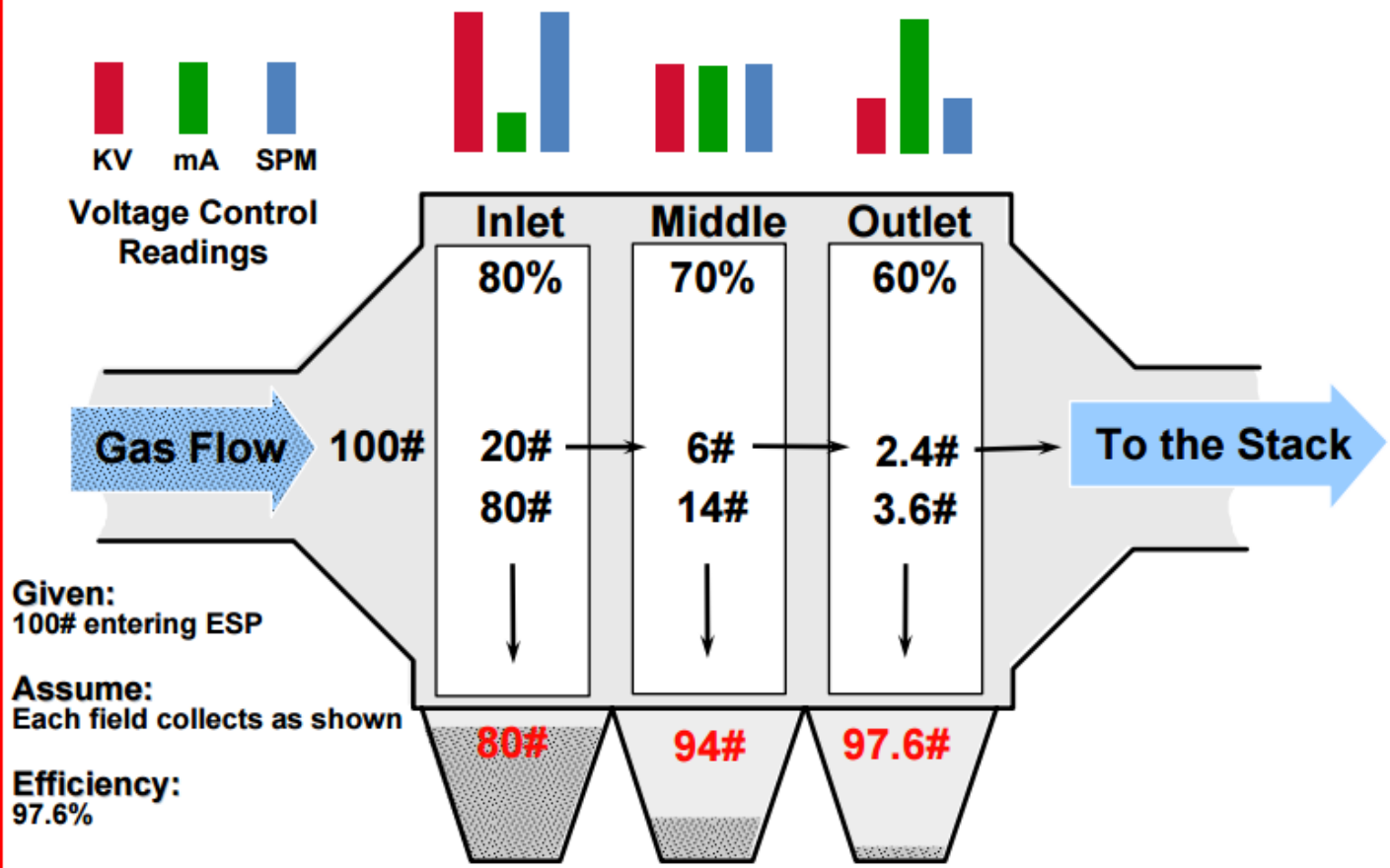

Values shown are to represent relationship only...not necessarily actual conditions

## Typical Trends for all ESP's

*Always look for  
this trend...*

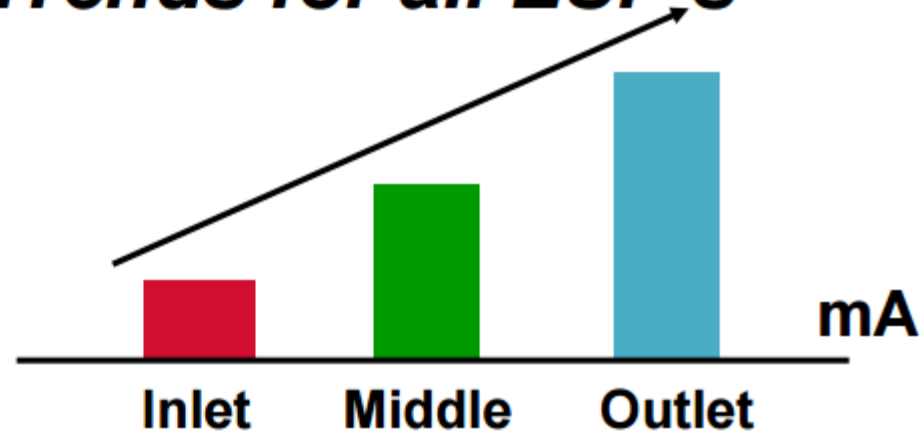

*Decreasing KV per Unit Current and SPM, from inlet to outlet, also should show*

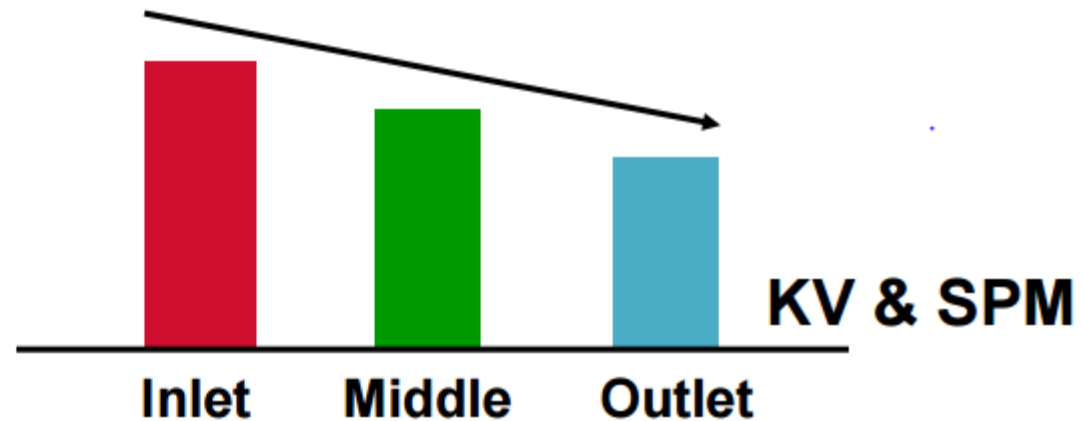

# *Is This ESP Behaving Properly?*

**Good Dust**

**AVC Readings**

AVC	AMPS	VOLTS	mAMPS	KV	SPM
1	60	365	300	43	30
2	90	350	500	38	30
3	240	345	1390	40	10
4	240	310	1450	39	0

# Thank You